

H160

Dimensions/mm

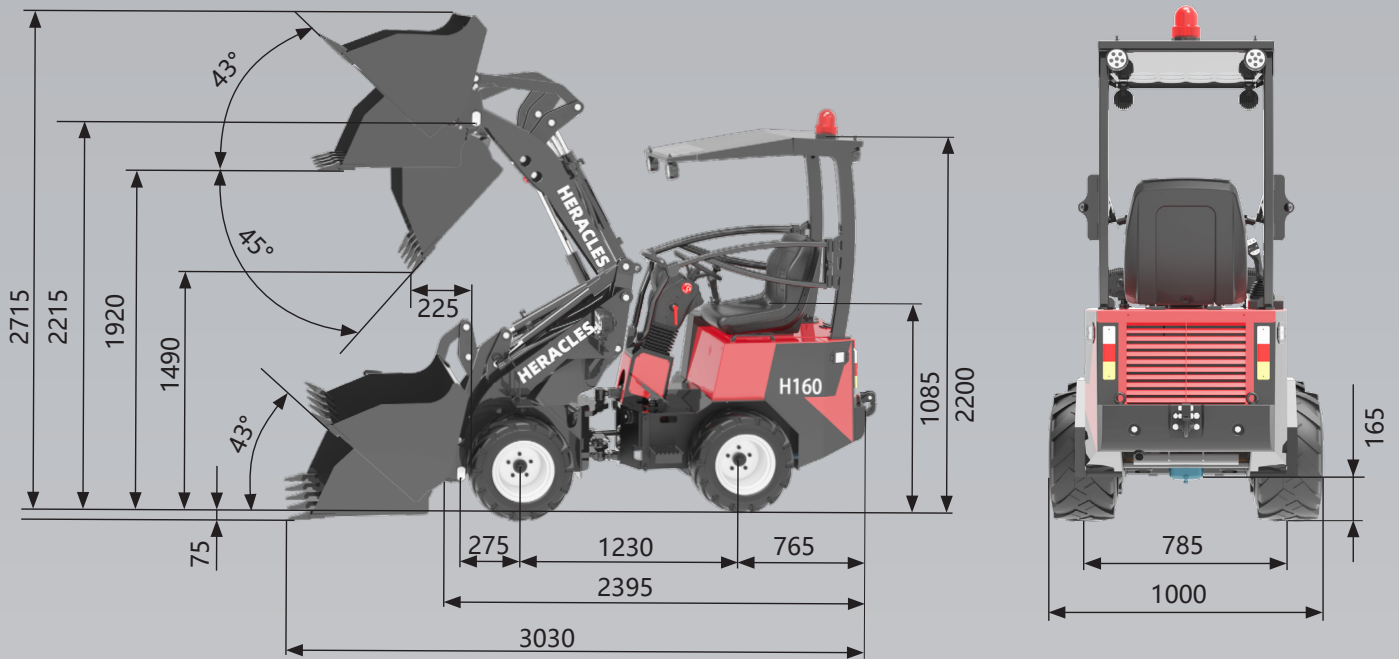

Tires size	Height	Width
23x8.50-12NHS-4TL	2200	1000
24x12.00-12NHS-4TL	2215	1200

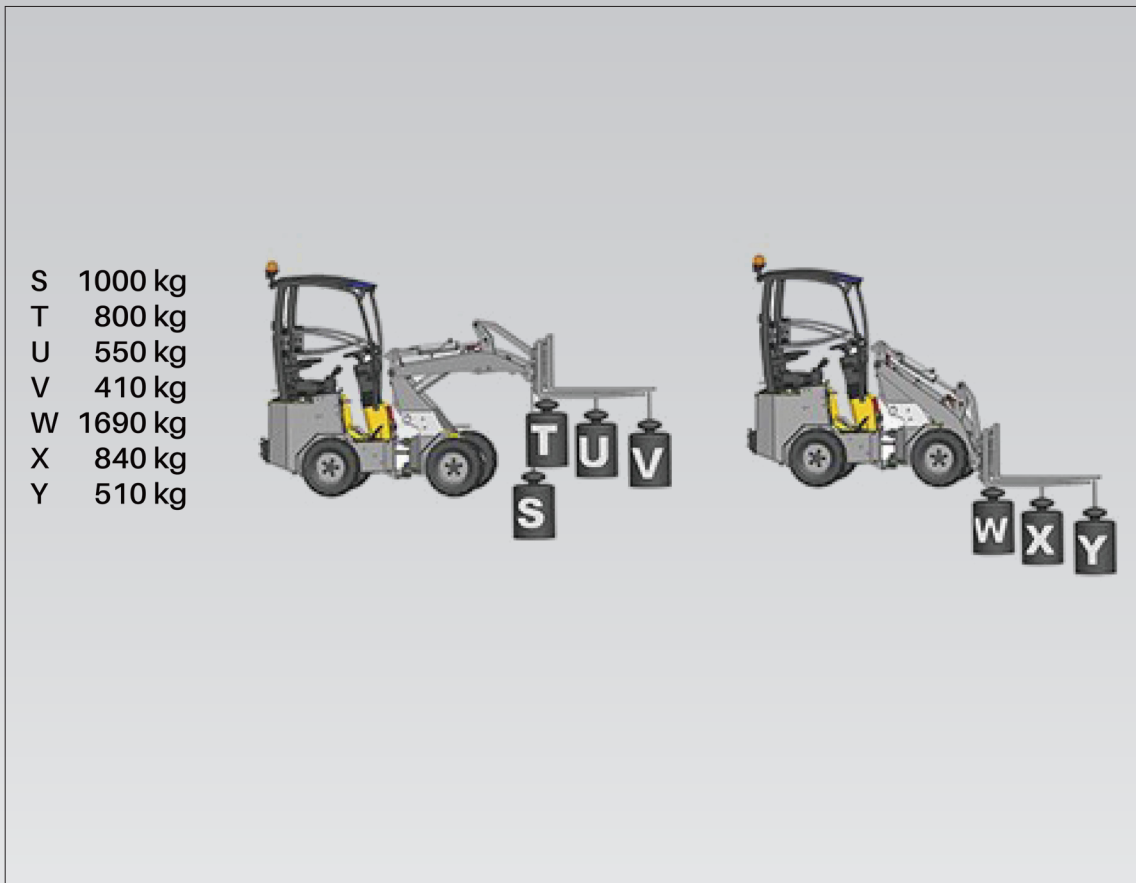





Products will continue to be optimized, so the technical data on this page may not be updated in real time.
 For more information at: www.heracles.eu
 Or contact us (contact information is on the back cover).



H160T

Technical data



 Max Lifting Capacity	 Engine Power	 Travel Speed	 Hydraulic Flow	 Max Lifting Height
600 kg	18.4 kw	15 km/h	36 l/min	2.5 m



Technical data	H160T		
Engine model	Kubota D1105	Perkins 403J-11	YANMAR 3TNV80F-SDWB
Fuel type	Diesel		
Cylinders	3		
Displacement cc	1123	1131	1267
Emission standards	EU Stage V&EPA Tier 4 Final		
Max engine output kW	18.2@3000rpm	18.4@2800rpm	18.2@3000rpm
Max engine torque Nm	70.4@2200rpm	66.9@2100rpm	60~64@1900(+/-100/100)rpm
Cooling system	Water		
Operating voltage V	12		
Battery Ah	45		
Operating weight kg	1180		
Tipping load ,max kg	800		
Lifting capacity,max kg	600		
Operator's cab	Canopy		
Travel speed km/h	0~15		
Steering angle °	45		
Turn radius inside/outside mm	940/2030		
Standard tires	23x8.50-12NHS-4TL		
Fuel tank capacity l	40		
Hydraulic oil tank capacity l	50		
Working hydraulic flow l/min	36		
Working hydraulic pressure bar	180		
Transmission type	Hydrostatic		